

RoHS

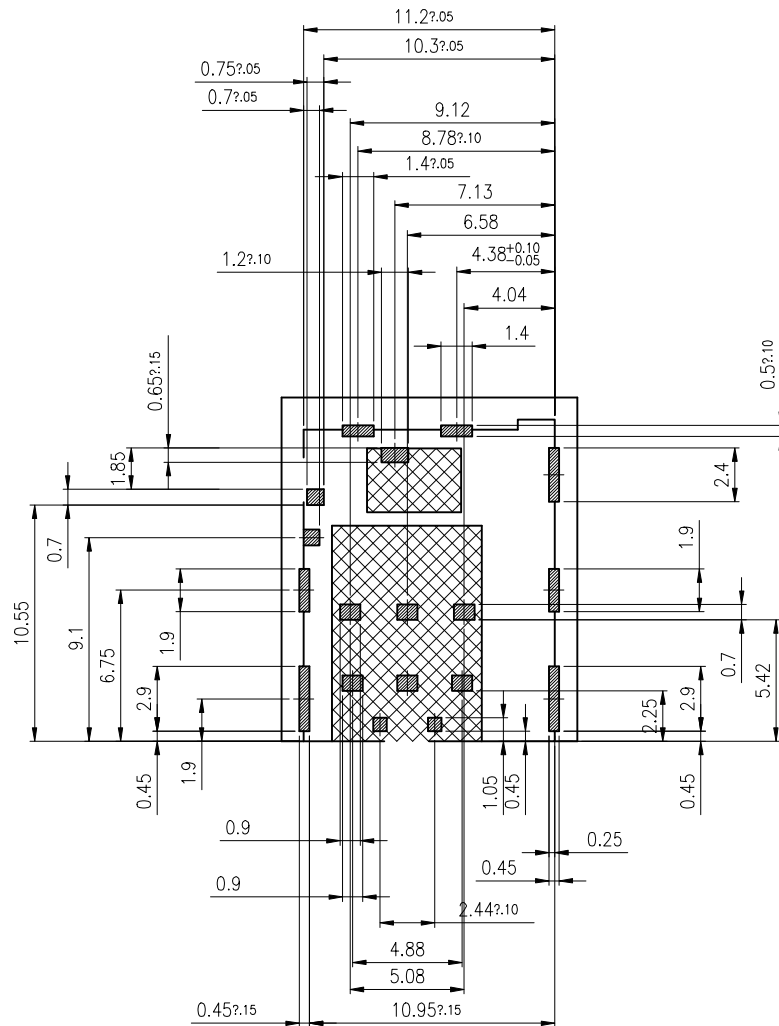

RECOMMENDED PCB LAYOUT TOP VIEW (TOLERANCE:±0.05)
RECOMMENDED MATAL MASK T=0.12MM

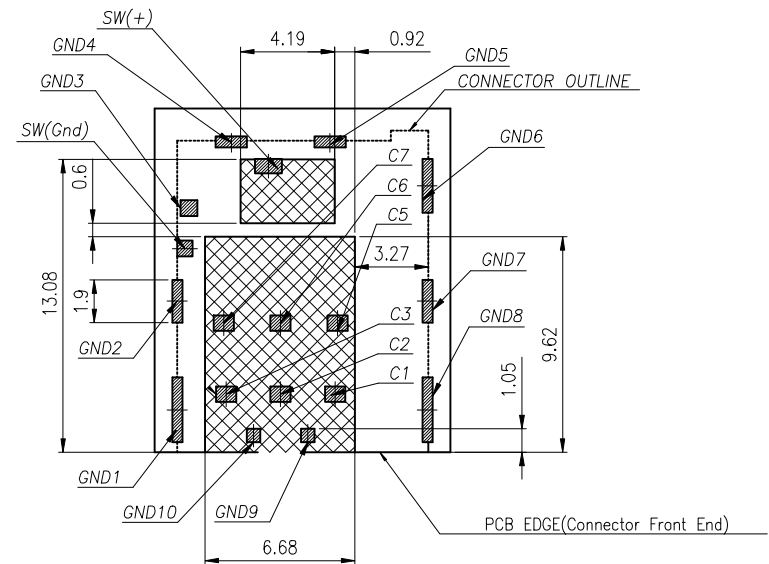

NO PATTERN AND VIA HOLE IN HTIS AREA
 SMT SOLDER AREA

MILLIMETERS	INCH	UNITS	深圳市连欣科技有限公司		
X° ± 2°	X° ± 2°	MM	DWG NO.: LXSM-102322824-00		TITLE: XAND SIM GPIN HL 25MM P/P客户图
.X ± 0.25	.XX ± 0.012	MAT'L	APPD:		PART NUMBER: XDSM-1023-2824
.XX ± 0.20	.XXX ± 0.008	SEE NOTES	CHKD:		SCALE: 1:1
.XXX ± 0.10	.XXXX ± 0.004	FINISH	DR:		SHEET: 2/3
<small>THESE DRAWINGS AND SPECIFICATIONS ARE THE PROPERTY OF Dong Guan Jin Bi Lai Electronic Co.,Ltd COPIED OR USED IN ANY MANNER WITHOUT THE PRIOR WRITTEN CONSENT OF Dong Guan Jin Bi Lai Electronic Co.,Ltd</small>		QTY	REV.:		X2
		SEE NOTES			

RoHS

USER DIRECTION OF UNREELING →

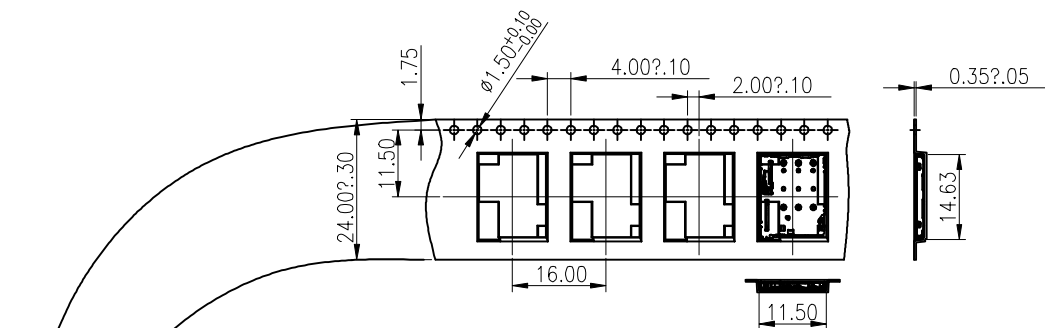

NOTES

1. NUMBER OF CONNECTORS: 2000PCS/REEL
2. LEAD TAPE LENGTH

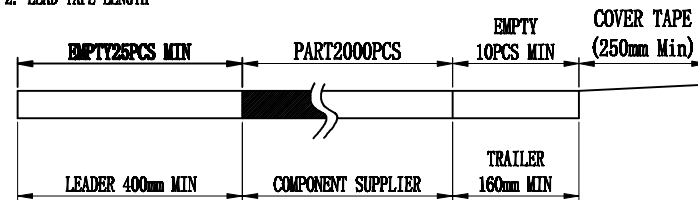

3. QUANTITY: 20000PCS/CARTON

COVER TAPE PEELING ANGLE: 165°~180°
PEELING FORCE: 20~130g
CARRIER TAPE

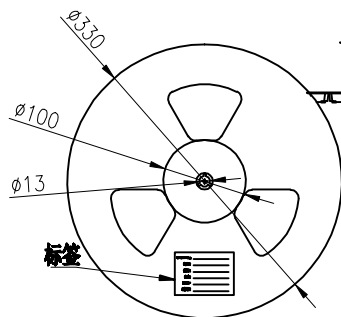

Each top of the bottom of the carton is protected by a piece of pearl cotton

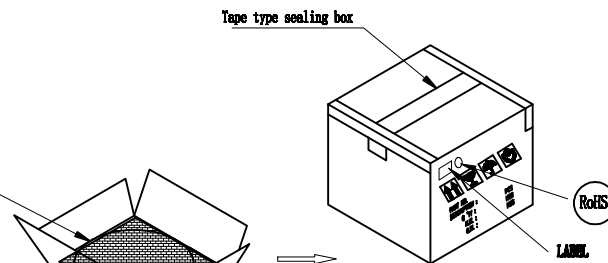
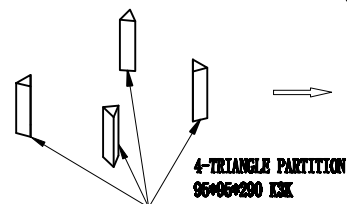

10 rolls per carton

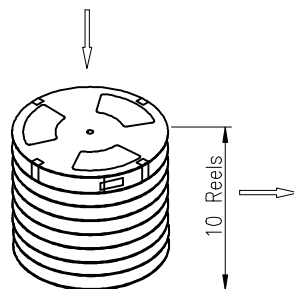
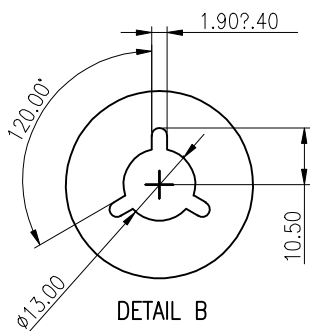

MILLIMETERS	INCH	UNITS	MM	深圳市连欣科技有限公司		
X. ^o ± 2'	X. ^o ± 2'	MAT'L		DWG NO. LXSM-102322824-00		TITLE: NANO SIM 6PIN HL 25MM P/P客户图
.X ± 0.30	.XX ± 0.012	SEE NOTES		APPD:		PART NUMBER: XDSM-1023-2824
.XX ± 0.20	.XXX ± 0.008	FINISH		CHKD:		SCALE 1:1
.XXX ± 0.10	.XXXX ± 0.004	SEE NOTES		DR:		SHEET 3/3
THESE DRAWINGS AND SPECIFICATIONS ARE THE PROPERTY OF Dong Guan Jin Bi Lai Electronic Co.,Ltd. COPIED OR USED IN ANY MANNER WITHOUT THE PRIOR WRITTEN CONSENT OF Dong Guan Jin Bi Lai Electronic Co.,Ltd				QTY		REV. X2